

# **Kate Andrews High School**



**New Student  
Information Package**

## Table of Contents

Welcome to Kate Andrews .....	Page 3
Contact Information .....	Page 3
Staff Directory .....	Page 4
School Map.....	Page 5
Supply List .....	Page 6
Bell Times.....	Page 7
School Calendar.....	Page 8-9
School Fees .....	Page 10
Student Supports.....	Page 11
Staying Informed .....	Page 12
Parent/Student PowerSchool Portal .....	Page 13
Advisory Home Room .....	Page 13
Expectations and Policies	
Attendance.....	Page 14
Lates .....	Page 14
Student Responsibilities.....	Page 14
Restricted Substances.....	Page 15
Dress Code .....	Page 15
Cellphones & Electronic Technology Policy .....	Page 15
Noon hour .....	Page 15
Clubs .....	Page 16
Athletics .....	Page 16
Athletic Player Eligibility .....	Page 16
Grade 9 Course Descriptions.....	Page 17-18
Knowledge & Employability Courses .....	Page 19
High School Diploma Requirements .....	Pages 20
Certificate of Achievement Requirements.....	Page 21
Senior High Course Descriptions .....	Page 22-24

# Kate Andrews High School

# Welcome to KAHS

**Motto:** In Pursuit of Excellence

**Mission:** Educating students in a caring environment that challenges each to find academic and personal success.

This booklet has been assembled to provide students and parents with an overview of our school and some basic information about the grade 9 program that we offer. It also includes school policies, course descriptions and Alberta High School Diploma requirements.

Due to the current COVID-19 pandemic, there are many unknowns. Unfortunately, we are not able to host our usual New Student Orientation or our parent information nights in June.

Please stay up to date by checking your email, our website, and our Facebook page regularly.

- More information will be sent out near the end of June and the end of August.

We look forward to meeting our new students and their parents. We want to make the transition from middle school to high school as smooth as possible. Students and parents are encouraged to contact the school if they have any questions.

## **Contact Information**



**2112—21 St. Coaldale Alberta T1M 1L9**

**Phone: 403-345-3383**

**Fax: 403-345-5767**

**Website: [www.kateandrewshighschool.com](http://www.kateandrewshighschool.com)**

**Facebook: Kate Andres High School**



---

## **Palliser School Division Contact Information**

**Palliser School Division**

**#101, 3305-18 Avenue North, Lethbridge Alberta**

**Phone: 403-328-4111**

**Toll-free: 877-667-1234**

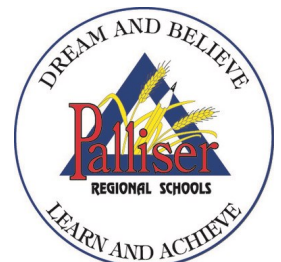
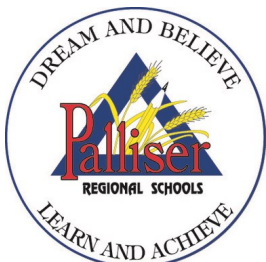

# Kate Andrews School Staff

## Administration

Daniel Grimes	Principal
Kris Van Wieren	Vice Principal
Darby Bell	Administrative Assistant
Kristy Darby	Administrative Assistant

## Counselling Services

Melinda Greenaway	Family School Liaison Counsellor
Jessica Hoffman	Family Connections Worker
Jo-Anna Meurs	Career and Academic Counsellor

## Teaching Staff

Kim Alexander	English/CALM/Drama
Arlene Arroyo	Math
Robyn Baraniecki	Science/Chemistry/Physics/Biology
Colleen Davies	English/Social Studies
Scott Godin	Band/Guitar/French/Financial Management
Dan Griffith	Construction/Fabrication/Mechanics/Math
Annalee Hamilton	Social Studies
Nicole Hanna	Math 9/Media/Physical Education
Paige Hierath	Art
Kelly Hurley	English/Forensics
Caitlin Mattatall	Science
Jo-Anna Meurs	Math/Science
Scott Oikawa	English
Clayton Ressler	Physical Education/Athletic Director
Angie Roelofs	Foods/Fashion/Cosmetology
Rebecca Rosen	Social Studies
Kendell Wiens	Math/Science/Physical Education

## Support Staff

Maxine Janzen	EA
Theresa Neufeld	EA
Lorri Penner	EA
Terry Urton	EA
Paddie Walmsley	EA
Bridgette Wiersema	EA
Gina Wittebolle	Librarian
Debbie Roth	Custodian
Tanya Wurzer	Head Caretaker
Kathleen Neufeldt	Custodian

**PRIDE**

**KATE ANDREWS**

# School Map

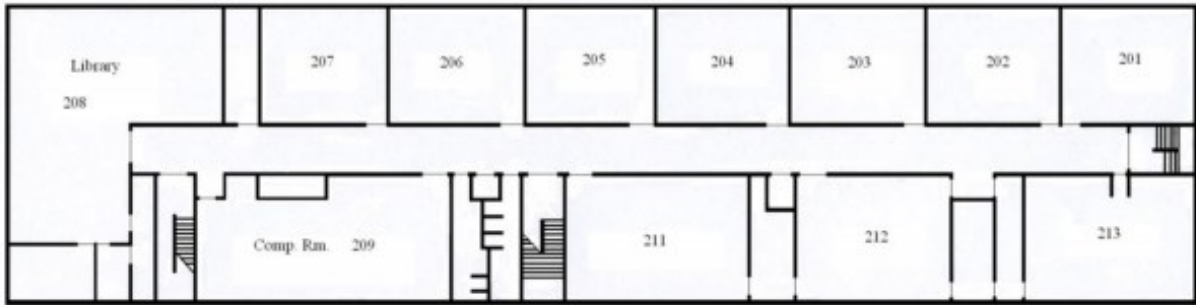

Second Floor

## Kate Andrews High School

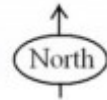

Main Floor





# KATE ANDREWS HIGH SCHOOL

2112 – 21 Street, Coaldale, Alberta, Canada T1M 1L9

Phone: 403-345-3383 Fax: 403-345-5767

www.kateandrewshighschool.com

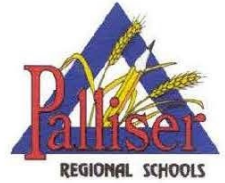

## RECOMMENDED SUPPLY LIST

*It is recommended that each student bring these basic supplies with them. Additional supplies may be required for specific classes, and will be requested by the teacher.*

- One 2”-3” Binder/Subject
- Three packages of Dividers
- Paper, pens, pencils (2H – 4H), and Whiteout
- Self containing pencil sharpener
- Three highlighters of different colours
- USB Key (4 Gigabyte size and up)
- One package of pencil crayons (optional)
- One Geometry set
- One pair scissors
- One glue stick
- One scientific calculator (Math 8/9) OR TI-83 or higher (for Math 10C and up)
- One package graph paper
- One set of Gym attire (shirt, shorts, shoes)
- Grade 9 – One Coil Bound Notebook (200 pages recommended)
- Other specific items as noted per class outlines



**KATE ANDREWS HIGH SCHOOL**



# BELL TIMES 2020-21

MONDAY - THURSDAY	
<b>Period 1</b>	<b>8:36- 10:03</b>
<b>Advisory Homeroom</b>	<b>10:05-10:15</b>
<b>Period 2</b>	<b>10:17 - 11:44</b>
<b>LUNCH</b>	<b>11:44 - 12:24</b>
<b>Period 3</b>	<b>12:24 - 1:52</b>
<b>Period 4</b>	<b>1:57 - 3:25</b>
<i>Grade 9 students have a 5 minute break during each period.</i>	
FRIDAY	
<b>Period 1</b>	<b>8:36 - 9:30</b>
<b>Advisory Homeroom</b>	<b>9:30 - 9:40</b>
<b>Period 2</b>	<b>9:40 - 10:34</b>
<b>Period 3</b>	<b>10:34 - 11:28</b>
<b>Period 4</b>	<b>11:28 - 12:22</b>



# KATE ANDREWS HIGH SCHOOL

## 2020-2021 SCHOOL YEAR CALENDAR - BOARD APPROVED - November 26, 2019

LEGEND:	DAY 1	DAY 2	DAY 3	DAY 4	EXAM BREAK	
<b>Aug-20</b>						
3	4	5	6	7		
10	11	12	13	14		
17	18	19	20	21		
24	25	26	27	28		
31						
<b>Sep-20</b>						
	1	2	3	4		
7	8	9	10	11		
14	15	16	17	18		
21	22	23	24	25		
28	29	30				
<b>Oct-20</b>						
			1	2		
5	6	7	8	9		
12	13	14	15	16		
19	20	21	22	23		
26	27	28	29	30		
<b>Nov-20</b>						
2(D)	3(D)	4(D)	5(D)	6(D)		
9(D)	10	11	12	13		
16	17	18	19	20		
23	24	25	26	27		
30						
<b>Dec-20</b>						
	1	2	3	4		
7	8	9	10	11		
14	15	16	17	18		
21	22	23	24	25		
28	29	30	31			
<b>Jan-21</b>						
				1		
4	5	6	7	8		
11(D)	12(D)	13	14	15		
18	19	20 (D)	21 (D)	22 (D)		
25 (D)	26 (D)	27 (D)	28 (D)	29		
<b>Feb-21</b>						
1	2	3	4	5		
8	9	10	11	12		
15	16	17	18	19		
22	23	24	25	26		
<b>Mar-21</b>						
1	2	3	4	5		
8	9	10	11	12		
15	16	17	18	19		
22	23	24	25	26		
29	30	31				
<b>Apr-21</b>						
			1	2		
5	6	7	8	9		
12(D)	13(D)	14(D)	15(D)	16(D)		
19(D)	20(D)	21	22	23		
26	27	28	29	30		
<b>May-21</b>						
A 3	4	A 5	6	7		
10	11	12	13	14		
17	18	19	20	21		
24	25	26	27	28		
31						
<b>Jun-21</b>						
	1	2	3	4		
7	8	9	10 (D)	11 (D)		
14	15	16	17 (D)	18 (D)		
21	22 (D)	23 (D)	24 (D)	25 (D)		
28 (D)	29	30				
<b>Jul-21</b>						
			1	2		
5	6	7	8	9		
12	13	14	15	16		
19	20	21	22	23		
26	27	28	29	30		

### NON-INSTRUCTIONAL DAYS

<b>Division-Wide PD Days</b>	<b>Collective Agreement Teacher Directed Days</b>	<b>Prof. Development (ATA)</b>
Opening Ceremony August 31, 2020	August 28, 2020 and June 29, 2021	Teachers' Convention -
September 21, 2020 (Summit Day)	<b>Site PD Days</b>	February 18 and 19, 2021
November 20, 2020	August 26, 27 and September 1, 2020	
March 19, 2021	January 29, 2021	<b>School PD Days</b>
	May 21, 2021	October 2, 2020
	June 28, 2021	April 30, 2021

		LEGEND
School year begins: August 26, 2020	XX	No Staff/Students
First day for students: September 2, 2020		Prof. Dev. Days (Palliser Directed)
Semester 2 begins: February 1, 2021		Site Based Prof. Dev. Days
Last day for students: June 25, 2021		Summer Break
		Collective Agreement Teacher Directed Days
		Teachers' Convention - ATA PD
		School PD Days

SCHOOL YEAR	INSTRUCTIONAL DAYS	Diploma Exams (D)	Nov.	Jan.	Apr.	June
181 Instructional Days	91 Semester 1	English LA 30-1 & 30-2A	2	11	12	10
14 Non-instructional Days	90 Semester 2	English LA 30-1 & 30-2B	4	21	14	18
195 Total Operational Days	181 Total Instructional Days	Social Studies 30-1 & 30-2A	3	12	13	11
<b>Achievement Tests (A)</b>	<b>Grade 9</b>	Social Studies 30-1 & 30-2B	5	22	15	22
English Language Arts Part A	May 3, 2021	Math 30-1 Math 30-2	6	20	16	17
English Language Arts Part B		Physics 30	9	27	20	25
Mathematics		Chemistry 30	6	26	19	24
Science		Biology 30	9	25	16	23
Social Studies		Science 30	N/A	28	19	28

Please note: Achievement and Diploma Exam schedules are as of January 2019. General Information Bulletin published by Alberta Education.



## KAHS 2020–2021

### Summary of School Calendar at a Glance for Students and Parents

#### **The KA Schedule Class Schedule is based on a 4 Day rotation.**

This means that classes are not always the same on a given day during the week. (*Generally, Days 1 & 3 are the same, and Days 2 & 4 are the same, but there are some exceptions to this rule.*) The first day of a semester is Day 1, The second day is Day 2 and so on. PD Days, Holidays or other days off school do not count in the rotation, so the next school day just continues with the 1, 2, 3, 4 pattern.

#### **The DAY # is always posted in front of the office in case students forget.**

**Wednesday, September 2<sup>nd</sup>** – First Day of Semester 1 Classes

**Friday, January 15<sup>th</sup>** – Last Day of Semester 1 Classes

**January 18<sup>th</sup> - 28<sup>th</sup>** - Semester 1 Final Exam Break

**Monday, February 1<sup>st</sup>** – First Day of Semester 2 Classes

**Friday, June 11<sup>th</sup>** – Last Day of Semester 2 Classes

**June 14<sup>th</sup> – 25<sup>th</sup>** - Semester 2 Final Exam Break

#### **FINAL EXAM BREAKS**

There will be no classes during this time, but students are required to attend their scheduled final exams. Many Grade 9 Final Exams will happen during class, rather than during Exam Break.

Teachers are still at school, and able to help students upon request. ***\*Please note:*** teachers do have exam supervising duties during this time so it is important to schedule a time with a specific teacher prior to coming to the school for assistance.

#### **There is NO SCHOOL on the following days:**

**Monday, September 7<sup>th</sup>** (Labour Day)

**Monday, September 21<sup>st</sup>** (Division-Wide PD Day)

**Friday, October 2<sup>nd</sup>** (Site-Based PD Day)

**Monday, October 12<sup>th</sup>** (Thanksgiving Day)

**Wednesday, November 11<sup>th</sup>** (Remembrance Day)

**Friday, November 20<sup>th</sup>** (Division-Wide PD Day)

**December 21 – January 4<sup>th</sup>** (Christmas Break)

**February 15 – 19** (Reading Week Break & SWATCA for Teachers)

**Friday, March 19<sup>th</sup>** (Division-Wide PD Day)

**April 2<sup>nd</sup> – 9<sup>th</sup>** (Easter Break)

**Friday, May 21<sup>st</sup>** (Site-Based PD Day)

**Monday, May 24<sup>th</sup>** (Victoria Day)



# KATE ANDREWS HIGH SCHOOL

2112 – 21 Street, Coaldale, Alberta, Canada T1M 1L9  
Phone: 403-345-3383 Fax: 403-345-5767  
www.kateandrewshighschool.com



## SCHOOL FEES: 2020-2021 SCHOOL YEAR

**The Grade 9 fee of \$102.00 and the Grades 10 – 12 Fee of \$40.00** are due before students receive their lockers, books and opening day packages on their **\*\*Registration Day**. **\*\*Information regarding Registration Days will be shared as soon as specific plans are known. Watch the KA Website and your email for updates.**

**Fees for the 2020/21 School Year will be posted to SchoolCashOnline by August 14, 2020.**

Palliser Regional Schools uses SchoolCashOnline for School Fees, Athletic Fees, and other program fees throughout the school year. Cash or cheques are accepted in the office if you are not able to use SchoolCashOnline, however we strongly encourage online payments. *The link for SchoolCashOnline can be found on the KA Webpage.*

BASIC SCHOOL FEES		
Grade 9	\$102.00	Palliser Technology Fee (\$35.00) Food Studies (\$31.00) Industrial Arts/Shop (\$31.00) Student Council Activity Fee (\$5.00)
Grade 10-12	\$40.00	Palliser Technology Fee (\$35.00) Student Council Activity Fee (\$5.00)
All Students	\$20.00	Experiential Learning Week (ELW) Fee <i>(Will be charged in Semester 2, only if ELW occurs.)</i>
PER COURSE FEES (Applies to Grade 10-12 ONLY): <i>(these fees pay for specific costs incurred for the class for supplies, field trips, etc.)</i>		
Grades 10 – 12	\$20.50	Cosmetology
Grades 10 – 12	\$20.50	C.A.L.M. 20
Grades 10 – 12	\$31.00	Art
Grades 10- 12	\$31.00	Construction/Fabrication
Grades 10- 12	\$31.00	Electronics
Grades 10- 12	\$31.00	Mechanics
Grades 10 – 12	\$31.00	Fashion Studies
Grades 10 – 12	\$31.00	Food Studies
Grades 10 – 12	\$41.00	Physical Education
Grades 10 – 12	\$31.00	MUSIC - BAND
Grades 10 – 12	\$20.50	MUSIC - CHOIR
Grades 10 – 12	\$20.50	MUSIC - GUITAR
Grades 9 – 12	\$100.00	Instrument Rental
Grades 9 – 12	\$550.00	Hockey Academy
OPTIONAL FEES		
Grade 9 – 12	\$41.00	Yearbook

**All BASIC School Fees are due before school begins. Students who have outstanding fees from previous years or who have not paid the Basic School Fees (\$102 for Grade 9 or \$40 for Grade 10-12) WILL NOT receive text books until these fees are paid.**

*Most Grade 9 students are registered in both Foods & Industrial Arts. The fee will be removed for any student who is not taking these courses.*

**We want students to have books! Any families who are experiencing financial difficulties and as such are not able to pay basic school fees before classes begin, are encouraged to speak with Mr. Grimes to discuss payment plans or other options.**

The **Per Course fees** (which apply only to Grades 10-12) for the first semester will be invoiced on September 30<sup>th</sup>, 2020 and then on February 26<sup>th</sup>, 2021 for the second semester.

The Per Course Fees pay for costs associated with specific supplies or services used in that particular class. (i.e. – groceries for Foods, wood or metal for Construction/Fabrication, Music for Band, Choir, Guitar, thread/machine maintenance and limited supplies for Fashion Studies or Field Trip costs for Phys. Ed.)

*Students in Grades 10-12 who drop courses after September 30<sup>th</sup>, 2020 and February 26<sup>th</sup>, 2021 respectively will forfeit their fee.*

**Athletic fees are separate from school fees and can be found in the athletics handbook. Athletic fees are due at the BEGINNING of each sport season.**

# Student Supports

**Advisor Program:** All students at Kate Andrews are assigned a teacher/advisor. Our Advisor time is 10 minutes long takes place between period 1 and 2. The Advisor program is designed to foster relationships among students and staff, where students have an adult in the building that can help them with academic programming, ongoing daily progress and it will function as the primary link between school and home. A student's advisor is a constant in the life of the student over his/her four year at Kate Andrews. Attendance is mandatory

**Family School Liaison Counselor (FSLC):** Melinda Greenaway is our Family School Liaison Counselor. She is specifically trained to assist students who experience social, emotional, or behavioral difficulties. Mrs. Greenaway works in cooperation with the KAHS teaching staff and school administration to provide support, consultation, counseling and referral services for students and their families. Please feel free to call the school, to send an email or stop by Miss. Greenaway's office anytime to set up an appointment.

**Family Connections Worker (FCW):** Kate Andrews currently has a Family Connections Worker to support families and independent learners stay connected with school and their community. Our FCW is here to support, guide and advocate for students and their families.

**Career and Academic Counsellor (CAC)** Kate Andrews' Career and Academic Counsellor supports students and families as they transition through high school. Although there are drop-in times available, it is advised that students/families set up an appointment when they are ready for sit down to discuss future plans. Our CAC is happy to help students out with work experience credits, scholarship information, understanding academic paths, high school credits and post-secondary supports.

**Learning Commons/Library:** Kate Andrews has created a more flexible learning space for students that lends itself reading books, magazines and newspapers; collaborative student-work table; computer use; a lounging spot and quiet area to de-stress.

**Textbook Centre** Textbook rentals will be distributed from the Textbook Centre at the beginning of each semester. Textbooks are to be returned to the bookroom at the end of each semester on the day that the course exam is being written. Any textbooks that are not returned will have to be paid by the students prior to receiving new textbooks.

# KATE ANDREWS



# PRIDE





# STAY INFORMED!



At Kate Andrews High School, we strive to keep students and their families informed about what is going in and around the school. **However, we do not send paper notifications home with students.** Instead, you can always stay informed in the following ways:



SCHOOLMESSENGER®

At KAHS we use **School Messenger** for parents to report **Attendance** like Absences or lates. Please download the app or you can phone attendance notifications to **1-844-260-7166**.

**EMAIL:** *Every student has a student email account that the office and teachers will send information/ notifications to. We will also occasionally send notifications to parents via email regarding things that are going on around the school. Teacher email addresses are listed on our website, and we encourage you to stay in contact with your child's teacher if you have questions or concerns.*

**KA Website:** [kateandrewshighschool.com](http://kateandrewshighschool.com)

We strongly encourage parents and students to check it out often to see what is happening around KA. The Athletics Schedule (games, practices, etc.) are always posted in the calendar section on the Athletics page. We update the **CALENDAR** and the **SCHOOL NEWS** sections almost daily.

Like "Kate Andrews High School" on Facebook to stay informed!



**DAILY ANNOUNCEMENTS** are made

*every day during ADVISOR so that students hear about important information pertaining to their day and also upcoming events. Students are also able to access Daily Announcements on the KA webpage.*



**KA NEWSLETTER:** The KA Newsletter is published around the 1<sup>st</sup> of every month. The newsletter is posted to the KA Website, and is also emailed to students and parents.

**Some teachers/clubs/teams use Apps like REMIND.** (There are a few different Apps out there.) These apps are communication tools that help teachers communicate with students and parents.



**TV Screens:** There are TV Screen's throughout the school (in the MAIN ENTRANCE, the LUNCHROOM and just outside of the LIBRARY that display important announcements and information.



Instagram

Follow @KAATHLETICS on twitter or KAathletics on Instagram for game/practice reminders and up-to-date results and announcements from our athletic department!

**Phone/School Messenger Voice Messages:** *If there is something that we need to speak with you about regarding your child, a teacher or administrator will contact you directly via phone. We also use School Messenger to distribute important voice messages to parents/guardians.*





At Kate Andrews High School, we are excited that we can now offer the Power School Parent/Student Portal as a way to view student grades and attendance online, LIVE! This means that you can now see if your student is marked late or absent from class, and even have a notification sent right to your phone the instant that your student is marked absent by the teacher. You now have a live link to your student's current grades as well as seeing if they have any missing assignments.

As a LIVE record of student attendance and grades is now available through the Power School Parent Portal, **hard copy Report Cards will no longer be mailed to parents or handed out to students.** We STRONGLY encourage all parents to sign up for the Power School Parent Portal.

Students do not need to sign up for their Student Portal Account. They simply need to log in to the P.S. Student Portal, using their Palliser Windows Computer log-in. If they have any difficulty logging in, they can come to the school office for assistance.

The "Power School Portal" tab on our webpage includes detailed instructions for creating your account as well as linking additional students to your account (i.e. if you have more than one child in Palliser Regional Schools). The KA office is also happy to assist any parents to set up their account. We can usually help over the phone, however we also have a Chrome Book set up in the office for parent use for this purpose.

*If you have a P.S. Parent Portal account for your child at R.I. Baker, this account should just roll over to KA, as the account follows the student.*

*At KA students are expected to attend an **Advisory Homeroom Class**. On a daily basis, we ask our students to meet with their Advisory Homeroom Teacher for 10 minutes between Period 1 and Period 2. This structure allows for us to do many things as a school when we want to organize our students for various functions. This is also when we share information, such as daily announcements with students.*

*More importantly, it creates a 'mechanism' which allows each student coming into grade 9 to have one teacher/adult in the building that would stay with that student for all 4 years in high school. The hope is that the student and teacher will have a connection, so as to ensure every child has at least one adult they can talk to when they really need it. This potential connection along with the Advisory Class can play a major role in providing opportunities to bolster student well-being in Kate Andrews. The benefits are huge and hopefully obvious to see. As our students build relationships with their advising teacher and other students, further opportunities will evolve which allow us to build school spirit. Building school spirit will be part of providing a positive social network for all students.*

Kate Andrews High School uses **SchoolCashOnline** for almost ALL financial transactions. If you do not already have one, we strongly recommend that you sign up for an account before your child begins classes.

**Base school fees are DUE BEFORE students will be given text books.** Please see the School Fees schedule for a complete list and details about school fees.

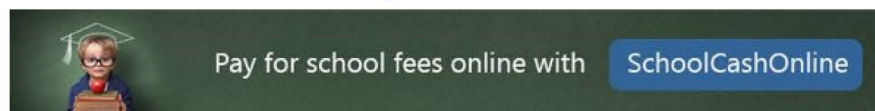

# Expectations and Policies

## Attendance

All students should be prompt and regular in attendance. The home is responsible for students attending school regularly and on time. After 5 unexcused absences, teachers will contact parents/guardians to engage in a conversation on the students' learning. Chronic attendance issues will result in administrative intervention which may include in-school and out-of-school suspensions or could result in removal from a course. For students in grades 10-12, attendance issues can jeopardize credits and ultimately, progress toward graduation.

Parents will be notified throughout the process of handling attendance issues. If a student will be absent or late, it is our expectation that parents inform the school in advance. Parents can use School Messenger to update their child's attendance. School Messenger can be accessed on the home page of our school website or by downloading the free mobile app. Parents can also call the school office to inform of any absences.

## Lates

Prompt attendance is required for all classes. It will be up to the discretion of the teacher to choose a cut-off point at which student will be marked with an unexcused absence in their class. For example, a student may be marked absent if they arrive to class 20 minutes after the bell.

## Student Responsibilities

The Province of Alberta School Act specifies the code of conduct that is to be expected from students. Section 12 states:

A student shall conduct himself so as to reasonably comply with the following code of conduct:

- (a) be diligent in pursuing his/her studies
- (b) attend school regularly and punctually
- (c) cooperate with everyone authorized by the board to provide education programs and other services
- (d) comply with the rules of the school
- (e) account to his/her teachers for his/her conduct
- (f) respect the rights of others.

Students of Kate Andrews High School have two basic responsibilities: respect themselves and others, and strive to do their best. Specific classroom rules may vary from room to room and you will receive these with your course outline. Teachers will use their own discretion and professional judgement when dealing with discipline issues.

We have high expectations for learning, behaviour and character for KAHS students. Students are expected to treat themselves, other students, staff, and their school with consideration and respect. Bullying, inappropriate language, disrespectful behaviour and vandalism are not permitted.

Administrative intervention will take place as result of student misbehaviour and can take a variety of forms based on the student and act. Student participation in extra-curricular activities and field trips may be subject to administrative approval if they are unable to follow the guidelines noted.



## Restricted Substances

Drugs, including alcohol, tobacco and marijuana, are not permitted on school property or at school functions, trips, or events. Use, possession, association with users, or other involvement with these substances will result in suspension, expulsion and/or criminal charges.

## Dress Code

Kate Andrews provides a safe and caring environment for staff and students. We respect the rights and freedoms of everyone in an inclusive environment. As such, we encourage that all members of our school community wear attire that is both clean and modest.

The following guidelines are there to assist students and parents in interpreting what "clean and modest" means.

- Clean means: The clothing is free from all references to drugs, violence, sexism, and racism. Clothing or accessories that could be classified as a potential weapon are not permitted (i.e., chains, spiked necklaces/bracelets, etc.).
- Modest means: Clothes are not too revealing regardless of one's gender or gender identity. Our preference is that clothing covers all undergarments. Considering that weather can become quite warm and at times make classrooms uncomfortable, we understand that students will wear shorts and t-shirts or tanks. Please consider the school context when choosing what you wear. The suggestion is to consider school as your place of work and ask yourself if the outfit is appropriate.

Deciding on appropriate dress is a subjective and personal decision. Kate Andrews' goal is to support the emotional well-being of all of its students and so we ask for parents and students to make informed decisions when deciding on appropriate dress for school.

In some circumstances the school may make contact with parents regarding the attire of their child to aid in making decisions about its appropriateness.

## Cellphones & Electronic Technology Policy

Kate Andrews High School embraces the potential that smart phones, cell phones, and other similar electronic devices have as a technological learning tool in the classroom. Teachers are permitted to implement the use of personal electronic devices to enhance planned curricular activities. Students may use their cell phones and electronic devices during transition periods, before and after school, and during spares and lunch. Students are not allowed to use cell phones and electronic devices in the classroom unless permitted to by a teacher. Any use of a technological device that disrupts the educational environment or is detrimental to the safety, welfare, or health of students and staff may result in disciplinary consequences. The use of electronic devices is a privilege and not a right and therefore, responsible use is expected and will be enforced.

## Noon hour

All students remaining in the school during noon hour are requested to eat their lunches in the lunchroom or other lunch eating designated areas. Eating on the front lawn, in the courtyard or in the hallways is permitted provided that students cooperate in keeping these areas free of litter by using the garbage receptacles.



## Clubs

Student Council	TBD
We Create Change	Mr. Gibson
GSA	Mr. Oikawa
Board Game Club	Mr. Wiens
Book Club	Mrs. Hurley
Alpha Club	Mr. Wiens
Travel Club	Ms. VanWieren

## Athletics

Cross Country, Golf, Volleyball, Basketball, Badminton, Curling

Track & Field, Baseball, Softball

### **Athletic Player Eligibility – Grade 9**

Grade 9 students participate in the Lethbridge Schools Athletic Association. Grade 9 students are ineligible to play in Alberta Schools Athletic Association (ASAA) sanctioned leagues – these leagues are exclusively for students in Grades 10-12.

### **Athletic Player Eligibility – Grades 10, 11, 12**

Eligibility for Extra-Curricular athletics at Kate Andrews for students in Grades 10-12 is determined by the regulations of both the Alberta Schools Athletic Association (ASAA) and by League constitutions.

- The competitor must be a bona fide student of an ASAA member school. A student becomes a bona fide student of a school on the first day of classes beginning the term or semester in the school in which he/she is registered. In case of transfer from one school to another the student shall become a bona fide student in the new school upon the date of his/her first attendance at classes following the acceptance of his transfer-in by the Principal.
- The competitor must register in a minimum of 800 instructional minutes per week during the time of participation in that activity for which Alberta Learning credits are granted. Distance education courses and courses taken at Palliser Beyond Borders may not be considered as regular instructional minutes.
- A student who becomes 19 before September 1 of the current year shall be ineligible for high school competition.
- It must be the opinion of the Principal of the school that it is in the best interest of the competitor and of the school as a whole for him or her to participate.
- Any student that has been registered at and attended a post-secondary institution shall not be eligible for high school competition.
- Students shall be eligible for three consecutive years after registering in Grade 10. The first year in Grade 10 is considered the first year of eligibility.

Students and parents can contact Mr. Ressler or Mr. Grimes if they have any questions in respect to eligibility.



# Grade 9 Course Descriptions

Grade 9 curriculum is based on the Alberta Education *Program of Studies: Junior High Schools*. The following course information has been taken directly from this document. A complete copy of this document may be obtained from Alberta Education's website. <https://www.alberta.ca/programs-of-study.aspx>

## ENGLISH LANGUAGE ARTS 9

The aim of English Language Arts is to enable each student to understand and appreciate language, and to use it confidently and competently in a variety of situations for communication, personal satisfaction and learning. By the end of grade 9, students will listen, speak, read, write, view, and represent to: explore thoughts, ideas, feelings and experiences; comprehend and respond personally and critically to oral print and other media texts; manage ideas and information; enhance the clarity and artistry of communication; and respect, support and collaborate with others.

## MATHEMATICS 9

The main goals of mathematics education are to prepare students to:

1. use mathematics confidently to solve problems
2. Communicate and reason mathematically
3. Appreciate and value mathematics
4. Commit themselves to lifelong learning
5. Become mathematically literate adults
6. Use math to contribute to society.

In Math 9, students will solve problems involving powers and apply the order of operations, including exponents. They will solve problems involving operations on positive and negative fractions and decimals, and understand square roots of positive numbers. They will model and solve problems using linear equations and linear inequalities in one variable. They will also be introduced to polynomials and solve problems involving circle geometry and scale diagrams.

## SOCIAL STUDIES 9

Social studies helps students to learn basic knowledge, skills and attitudes needed to become responsible citizens and contributing members of society. Social studies includes the study of history, geography, economics, the behavioural science and humanities. Grade 9 social studies focuses on citizenship, identity and quality of life. Students will examine the relationship between Canada's political and legislative processes, and they'll examine the impact of these processes on governance, rights, citizenship and identity. Students will also explore issues of economics and their impact on quality of life, citizenship and identity in Canada and the United States.

## SCIENCE 9

In Science 9 students will work safely with chemicals to explain, interpret and extend their understanding of chemical theory. They also design, test and evaluate electrical devices that transfer and transform energy, and they explore the role of genes and DNA in the diversity of life. Students study space exploration and how science and technology are related. In this course students will be introduced to six major concepts: Diversity of Living Things; Fluids and Pressure; Heat Energy: Transfer and Conservation; Electromagnetic Systems; Chemical Properties and Changes and Environmental Quality. Each of these concepts emphasizes the nature of science and the relationship among science, technology and society.

## PHYSICAL EDUCATION 9

Students will take part in various activities that will help them lead a healthy, active lifestyle. They will participate in dance, games, gymnastics, individual physical activities and activities outside of school. Students will also discover how positive interactions, through fair play, leadership and teamwork, make physical activity more fun and productive.

## HOCKEY ACADEMY

\*Separate registration must be complete in advance.\*

Students in Hockey Academy have the opportunity to learn hockey skills, leadership, teamwork and fitness with the combination of on and off-ice training sessions. This program of choice is funded entirely by parents.

## FOODS 9

Students will learn about food production, food preparation, and meal planning. They will understand nutrition and healthy food choices, food costs and economics, and safe food handling techniques. Students will have the opportunity to participate in cooking, baking, and food presentation.

## ART 9

Students will get the chance to explore the art materials, processes, and ideas around creating and appreciating art. They will study art from different cultures and gain the basic vocabulary of art. A variety of mediums will be explored to give a broad range of experience in art making. Students will use their learning to plan and create student directed artworks.

## BAND 9

Band 9 is designed to develop well-rounded musicians, focusing on refining their musical and performance skills. Field trips include opportunities to perform at concerts and special events.

## FRENCH 9

This is an introductory course for students who wish to learn French as a second language. Students will start with the basics and build upon their skills. There is opportunity for students to continue learning French in grades 10-12.

## HEALTH 9

Students will understand how their choices today have a long-term effect. Students will take charge in encouraging their friends, community, and family to live a healthy lifestyle. They'll look at laws in place about health and safety and whether they think changes should be made. Addictions and unhealthy relationships are studied more deeply. Students will look at their career goals too.

## CODING 9

Coding 9 is designed for students with little or no programming experience. It aims to provide students with an understanding of the role computation can play in solving problems. It also aims to help students feel justifiably confident in their ability to solve puzzles and challenges that allow them to accomplish specific goals. Learning how to write code teaches individuals to blend logical and creative thought to solve problems.

## SKILLS 9

This course will take an introductory look at Mechanics, Construction, and Fabrication. Students will review how to safely use and care for tools and equipment. Further learning will involve researching, designing, and completing projects in the above fields.

## DRAMA 9

Step into the 'self-conscious free zone' for the opportunity to acquire lifelong skills that will build your confidence as you learn a variety of dramatic techniques. Imaginative exploration is done through movement, speech, improvisation, acting, technical theatre and theatre studies.

## GUITAR 9

Guitar 9 is for students at all skill levels. Students will learn the basics of playing guitar through studying music notation and chord symbols. The main objective of this course is to create enhanced appreciation for music

## KNOWLEDGE & EMPLOYABILITY (K&E) COURSES

Knowledge and Employability courses are available to students in grades 9 through 12 who meet specific criteria. Completion of these courses will result in the student achieving their Certificate of High School Completion. See page 14 for details of the requirements. These courses are intended to provide students with opportunities to experience success and become well prepared for employment, further studies, active citizenship and life-long learning through hands-on programming. Knowledge and Employability courses include and promote: a) workplace standards for academic, occupational, and employability skills, b) practical applications through on- and off-campus experiences and/or community partnerships, c) career development skills to explore careers, d) and interpersonal skills to ensure respect, support and cooperation with others at home, in the community and at the workplace.

Knowledge and Employability courses are designed to provide entry-level employment skills. Some students may transition successfully from Knowledge and Employability courses to other courses to achieve a high school diploma, or to post-secondary opportunities (e.g. some colleges, some apprenticeship programs). Reviewing each student's learning plan on an annual basis will assist in adjusting their goals and courses as needed.

# High School Diploma Requirements

<b>ALBERTA HIGH SCHOOL DIPLOMA GRADUATION REQUIREMENTS (ENGLISH)</b>
The requirements indicated in this chart are the <u>minimum</u> requirements for a student to attain an Alberta High School Diploma. The requirements for entry into post-secondary institutions and workplaces may require additional and/or specific courses.
100 CREDITS including the following:
ENGLISH LANGUAGE ARTS – 30 LEVEL (English Language Arts 30-1, 30-2)
SOCIAL STUDIES – 30 LEVEL (Social Studies 30-1 or 30-2)
MATHEMATICS – 20 LEVEL (Math 20-1, Math 20-2 or Math 20-3)
SCIENCE – 20 LEVEL ❶ (Science 20, Science 24, Biology 20, Chemistry 20 or Physics 20)
PHYSICAL EDUCATION 10 (3 CREDITS) ❷
CAREER AND LIFE MANAGEMENT (3 CREDITS) ❸
10 CREDITS IN ANY COMBINATION FROM:
<ul style="list-style-type: none"> <li>• Career and Technology Studies (CTS)</li> <li>• Fine Arts</li> <li>• Second Languages ❹</li> <li>• Physical Education 20 and/or 30</li> <li>• Locally developed/acquired and locally authorized courses in CTS, fine arts, second languages, Knowledge and Employability occupational courses ❺</li> </ul>
10 CREDITS IN ANY 30-LEVEL COURSE ( <u>IN ADDITION TO A 30-LEVEL ENGLISH LANGUAGE ARTS AND A 30-LEVEL SOCIAL STUDIES COURSE AS SPECIFIED ABOVE</u> ) ❻
<p>These courses may include:</p> <ul style="list-style-type: none"> <li>• 30-level locally developed/acquired and locally authorized courses</li> <li>• Advanced level (3000 series) in Career and Technology Studies courses</li> <li>• 30 level Work Experience courses ❼</li> <li>• 30 level Knowledge and Employability courses</li> <li>• 30 level Registered Apprenticeship Program</li> <li>• 30-level Green Certificate Specialization</li> <li>• Special Projects 30</li> </ul>

- ❶ The science requirement—Science 20 or 24, Biology 20, Chemistry 20 or Physics 20—may also be met with the 10-credit combination of Science 10 and Science 14.
- ❷ See information on exemption from the physical education requirement in the *Guide*.
- ❸ See information on exemption from the CALM requirement in the *Guide*.
- ❹ Students may earn any number of credits in the study of second languages, but only a maximum of 25 language credits may be used to meet the 100-credit requirement for the Alberta High School Diploma.
- ❺ Integrated Occupational Program (IOP) occupational courses may be used in place of Knowledge and Employability occupational courses to fulfill this requirement.
- ❻ 30-level English or 30-level social studies courses from a different course sequence may not be used to meet the 30-level course requirement.
- ❼ Students may earn any number of credits in Work Experience, but only 15 credits may be used to meet the 100-credit requirement for the Alberta High School Diploma.



# Certificate of High School Achievement Requirements

<b>CERTIFICATE OF HIGH SCHOOL ACHIEVEMENT REQUIREMENTS (ENGLISH)</b>
The requirements indicated in this chart are the <u>minimum</u> requirements for a student to attain a Certificate of High School Achievement. The requirements for entry into post-secondary institutions and workplaces may require additional and/or specific courses.
<b>80 CREDITS<sup>❶</sup></b> including the following:
ENGLISH LANGUAGE ARTS 20-2 OR 30-4
MATHEMATICS 10-3 OR 20-4
SCIENCE 14 OR 20-4
SOCIAL STUDIES 10-2 OR 20-4
PHYSICAL EDUCATION 10 (3 CREDITS) <sup>❷</sup>
CAREER AND LIFE MANAGEMENT (3 CREDITS) <sup>❸</sup>
5 CREDITS IN
<ul style="list-style-type: none"> <li>• 30-level Knowledge and Employability occupational course, or</li> <li>• 30-level Career and Technology Studies (CTS), or</li> <li>• 30-level locally developed course with an occupational focus</li> </ul>
AND 5 CREDITS IN
<ul style="list-style-type: none"> <li>• 30-level Knowledge and Employability Workplace Practicum course, or</li> <li>• 30-level Work Experience course<sup>❹</sup>, or</li> <li>• 30-level Green Certificate course<sup>❺</sup></li> <li>• Special Projects 30</li> </ul>
OR
<ul style="list-style-type: none"> <li>• 30-level Registered Apprenticeship Program (RAP) course<sup>❻</sup></li> </ul>

❶ To qualify for a Certificate of High School Achievement, students must successfully complete a minimum of one academic Knowledge and Employability course.

❷ See information on exemption from the physical education requirement in the *Guide*.

❸ See information on exemption from the CALM requirement in the *Guide*.

❹ Refer to the *Off-campus Education Handbook* for additional information.

❺ Refer to the Alberta Education Web site for additional Green Certificate information.

❻ Refer to the *Off-campus Education Handbook* for additional information.

## Sr. High Courses Offered (Gr.10-12)

Please note that students must receive a minimum of 50% to move on to the next course level. Grade 9 students will be given recommendations from their teacher in regards to which stream they should pursue in Sr. High.

### English Language Arts

ACADEMIC STREAM: (English 10-1, 20-1, 30-1)

These courses are specifically designed for the College/ University bound student. There is a heavy stress on communication skills and emphasis is placed on the interaction with literature.

REGULAR STREAM: (English 10-2, 20-2, 30-2.)

The purpose of this stream is to provide the student with a positive Language Arts experience and to prepare the student to be an effective communicator at College/Technical School and in the working world.

KNOWLEDGE & EMPLOYABILITY: (English 10-4, 20-4, 30-4)

This program is designed to develop student self-esteem and confidence with the communication process. Particular attention is given to developing skills and attitudes to enhance communication in the workplace and the community at large through hands-on learning.

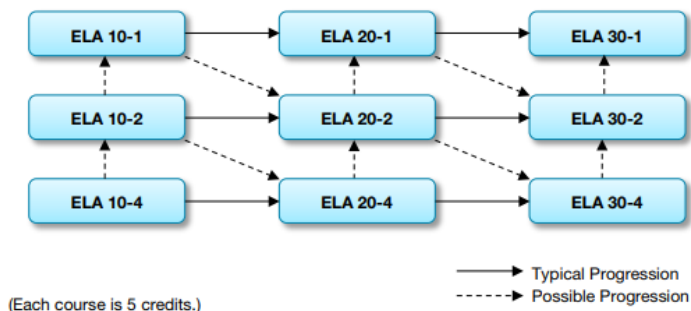

### Mathematics

ACADEMIC STREAM: (Math 10C, 20-1, 30-1)

These courses are required for entry into post-secondary programs at universities, colleges, and technical institutes that may require further study of mathematics. This stream is designed for students interested in careers emphasizing mathematics or sciences. (ex. Engineering, Mathematics, Sciences, Business)

REGULAR STREAM: (Math 10C, 20-2, 30-2)

This stream allows entry into many programs at universities, colleges, technical institutes, and apprenticeship programs. This sequence provides a student with a high degree of flexibility in terms of changing courses sequences—at both the Grade 11 and 12 levels—if the student’s interests change.

APPRENTICES & WORKPLACE STREAM: (Math 10-3, 20-3, 30-3).

These courses provide the knowledge and skills required for many apprenticeship programs as well as direct entry into the work force.

KNOWLEDGE & EMPLOYABILITY: (Math 10-4, 20-4)

Students in these courses will engage in measurements skills, number concepts and probability as they would be used in the workplace. Students will develop problem-solving and reasoning skills through hands-on learning.

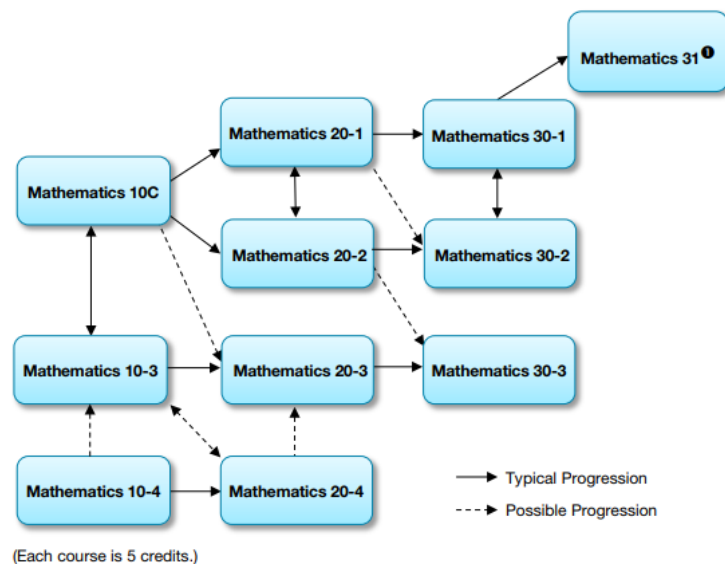

● Mathematics 30-1 is a prerequisite or corequisite for Mathematics 31.

## Sciences

SCIENCE 10: Introduces biology, chemistry, physics and global energy systems. Upon completion students will be able to choose one of or a combination of Biology 20, Chemistry 20 and/or Physics 20.

SCIENCE 20/30: Students will extend the application of biological, chemical, physical, and earth sciences and apply them to current world scenarios. They will analyze interactions in biological, chemical, physical, and global energy systems. These courses will enhance scientific literacy and prepare you for many post-secondary programs.

**Important:** Biology 20, Chemistry 20, Physics 20 or Science 20 can be used as a prerequisite to Science 30.

BIOLOGY 20/30: These courses will engage students in examining interactions of living systems with each other and their environment. Bio 20 emphasizes energy and matter exchange and Bio 30 focuses on adaptation and changes in biological systems. These courses will enhance scientific literacy and prepare you for many post-secondary programs.

CHEMISTRY 20/30: In Chemistry 20 & 30 students will engage with the study of matter and its changes in the natural and industrial worlds. These courses will enhance scientific literacy and prepare you for many post-secondary programs.

PHYSICS 20/30: Physics 20 & 30 will engage students in the exploration and analysis of the interactions between matter and energy. Students will understand the physics behind natural events and technology. These courses will enhance scientific literacy and prepare you for many post-secondary programs.

SCIENCE 14/24: In Science 14 and 24 students will apply scientific knowledge and skills to everyday experiences. These courses will satisfy the requirements for an Alberta High School Diploma. The Science 14/24 program is designed to emphasize the interrelationships between science, technology and society. These courses are suitable for students entering the workforce and some trades programs.

KNOWLEDGE & EMPLOYABILITY: (Science 10-4, 20-4). Students will apply scientific knowledge and skills to everyday life and the workforce through hands-on learning. Students will learn about systems of the human body, chemistry for the consumer, using systems and technologies, and managing the environment and resources.

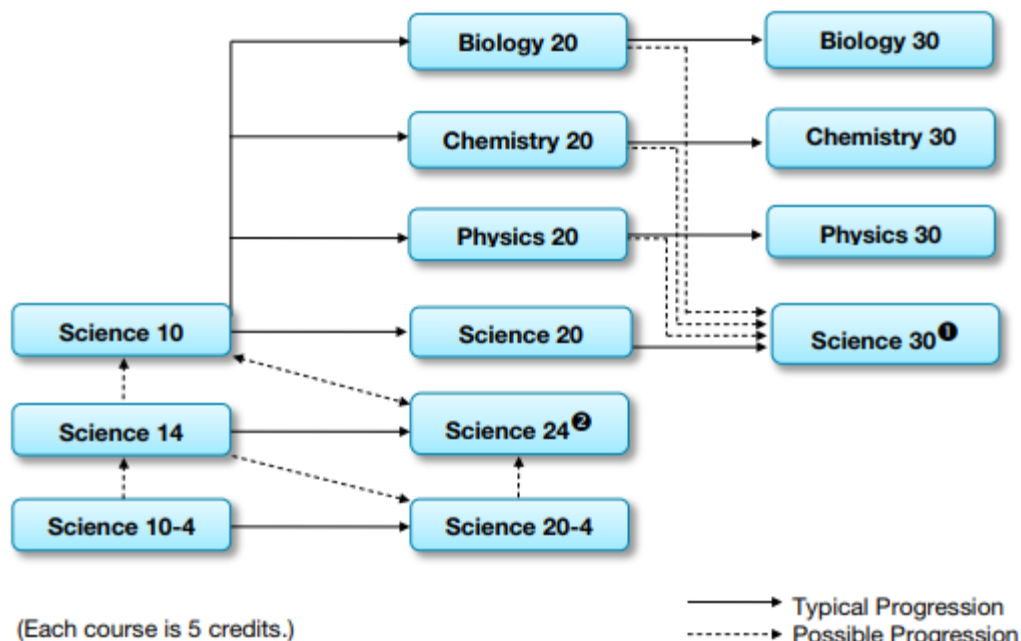

## Social Studies

Social Studies is the school subject where students develop the attitudes, skills and knowledge that will enable them to become engaged, active, informed and responsible citizens. Social studies is the study of people in relation to each other and to their world. It is an issues focused and inquiry-based interdisciplinary subject that draws upon history, geography, ecology, economics, law, philosophy, political science and other social science disciplines. Recognition and respect for individual and collective identity is essential in a pluralistic and democratic society. Social Studies will help students develop their sense of self and community, encouraging them to affirm their place as citizens in an inclusive, democratic society

ACADEMIC STREAM: (Social 10-1, 20-1, 30-1)

In general, those students who choose to take these courses would do so if they plan on attending university or some other post-secondary school where Social 30-1 is a requirement.

REGULAR STREAM: (Social 10-2, 20-2, 30-2.)

Students choosing this stream would likely do so if they plan on entering the work force or plan on attending post-secondary school where Social 30-1 is not a requirement.

KNOWLEDGE & EMPLOYABILITY: (Social 10-4, 20-4)

Students will connect their learning to everyday experiences as they respond to key questions about globalization and nationalism through hands-on learning. They will emphasize the importance of diversity and respect for differences to promote a sense of belonging and acceptance.

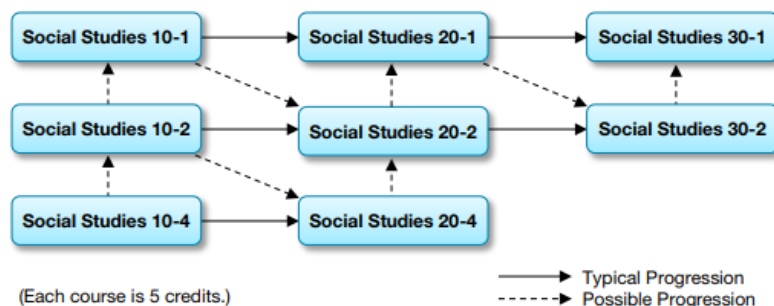

## CTS

- Foods 10/20/30
- Cosmetology 10/20/30
- Fashion Studies 10/20/30
- Construction/Fabrication 10/20/30
- Mechanics 10/20/30
- Media/Yearbook

## Fine Arts

- Art 10/20/30
- Drama 10/20/30
- Band 10/20/30
- Jazz Band 15/25/35

## Other Courses

- Wildlife
- Sports Medicine
- Psychology 20
- Forensics 25
- Leadership
- Hockey Academy

## Wellness

CAREER AND LIFE MANAGEMENT: CALM is designed to give senior high school students opportunities that will enable them to make well-informed, considered decisions and choices in all aspects of their lives and to develop behaviors and attitudes that contribute to the well-being and respect of others now and into the future. The course consists of three main themes: Personal Choices, Resource Choices and Career and Life Choices. CALM also includes one optional theme, human sexuality, which emphasizes personal and responsible decision making. Use of community venues and guest speakers are a vital part of the course.

PHYSICAL EDUCATION 10/20/30: PE supports students in acquiring a variety of developmentally appropriate movement activities. Students will gain experiences within various physical activities assisting you in further understanding health and wellness benefits, promoting positive interactions and leading an active lifestyle.

PHYSICAL EDUCATION 10 (ACTIVE LIVING): This is a 3 credit class designed for students to get their PE 10 credits completed in order to graduate. The class is intended to be an active living class, focussing on a non-competitive environment and more individual games/activities rather than team based. Personal health and fitness, and developing lifelong activity are the priority. This course is for students who do not wish to take PE 20 or 30 in the future.

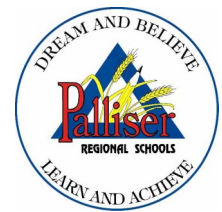

# KATE ANDREWS



# PRIDE

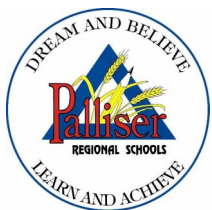

Stay up to date by following us on Facebook

@Kate Andrews High School

and on our website [www.kateandrewshighschool.com](http://www.kateandrewshighschool.com)

